

USER MANUAL



Greetings

Thank you for purchasing this product.

Please read this user manual for a safe and convenient experience.

In addition, this product may change due to product improvement without previous notice. In this case, product content descriptions and images may be different from corresponding descriptions and images in this user manual.

※ Please read safety precautions first and use the product appropriately.

※ Please keep this manual where users can read at any time.

※ Product image or content descriptions may change due to product improvements without previous notice.

Product Features



Leg massage unit
Independent movement
of each leg



Cycle mode



Quick On/Off
for each body part



15 safety sensors



Low-temperature burn
prevention feature



Stress Care



Mental Relaxation



Healthcare Massage



Favorites



Adjustable intensity
for each body part



Auto-connect
Bluetooth



Calf/sole heating



Heating massage ball



XD PRO



Blackout Protection
Button

XD PRO

XD PRO modules assess each part in 80 steps to provide a more sophisticated and personalized massage.

Separately moving leg massage unit

The left/right leg massage units move separately.

Improved Safety

There are 15 object-detecting sensors in the leg unit and back of the massage chair to improve safety for users.

Table of Contents

	Product Features	02
	Important Safety Instructions	04
Instructions Before Use	Grounding Instructions	05
	Safety Precautions	06
	Components and Descriptions	15
	Moving and Installation	16
	How to Connect the Product	17
How to Connect	How to Connect Wi-Fi (Software Update)	18
	Controller Button Descriptions	19
Controller Information	Controller Operation Instructions	21
	Rovo Mode · Healthcare Massage	30
Program Descriptions	Brain Massage · Mental Massage	31
	Auto Mode	32
Special Function Information	XD Module Description	33
Product Specifications	Product Size and Specifications	34
Customer Service and Troubleshooting	Customer Support Guidelines	35

Important Safety Instructions

When using an electrical appliance, basic precautions should always be followed, including the following: Read all instructions before using (this appliance).

⚠ DANGER - To reduce the risk of electric shock:

01 Always unplug this device from the electrical outlet immediately after use and before cleaning.

⚠ WARNING - To reduce the risk of burns, fire, electric shock or injury to persons:

- 01** An appliance should never be left unattended when plugged in. Unplug from outlet when not in use, and before putting on or taking off parts.
- 02** Do not operate under blanket or pillow. Excessive heating can occur and cause fire, electric shock, or injury to persons.
- 03** Close supervision is necessary when this appliance is used by, on, or near children, or disabled persons.
- 04** Use this appliance only for its intended use as described in this manual. Do not use attachments not recommended by the manufacturer.
- 05** Never operate this appliance if it has a damaged cord or plug, if it is not working properly, if it has been dropped or damaged, or dropped into water. Return the appliance to a service center for examination and repair.
- 06** Do not carry this appliance by supply cord or use cord as a handle.
- 07** Keep the cord away from heated surfaces.
- 08** Never operate the appliance with the air openings blocked. Keep the air openings free of lint, hair, and the like.
- 09** Never drop or insert any object into any opening.
- 10** Do not use outdoors.
- 11** Do not operate where aerosol (spray) products are being used or where oxygen is being administered.
- 12** To disconnect, turn all controls to the off position, then remove plug from outlet.
- 13** DANGER: Never use pins or other metallic fasteners with this appliance.
- 14** DANGER: Carefully examine the covering before each use. Discard the appliance if the covering shows any sign of deterioration, such as checking, blistering, or cracking.
- 15** DANGER: Keep Dry – Do not operate in a wet or moist condition.
- 16** WARNING: Temperatures sufficiently high to cause burns may occur regardless of the control setting. Do not use on an infant or disabled person or on a sleeping or unconscious person. Do not use on sensitive skin or on a person with poor blood circulation.
- 17** WARNING: Do Not Crush – Avoid sharp folds.

※ SAVE THESE INSTRUCTIONS

Grounding Instructions

This product must be grounded. If it should malfunction or breakdown, grounding provides a path of least resistance for the electric current so as to reduce the risk of electric shock. This product is equipped with a cord having an equipment-grounding conductor and a grounding plug. The plug must be plugged into an appropriate outlet that is properly installed and grounded in accordance with all local codes and ordinances.

⚠ DANGER

Improper connection of the equipment-grounding conductor can result in a risk of electric shock. Check with a qualified electrician or serviceman if you are in doubt as to whether the product is properly grounded. Do not modify the plug provided with the product - if it does not fit the outlet, have a proper outlet installed by a qualified electrician.

This product is for use on a nominal 220-V circuit and has a grounding plug that looks like the plug illustrated in sketch a below. Make sure that the product is connected to an outlet having the same configuration as the plug. No adapter should be used with this product.

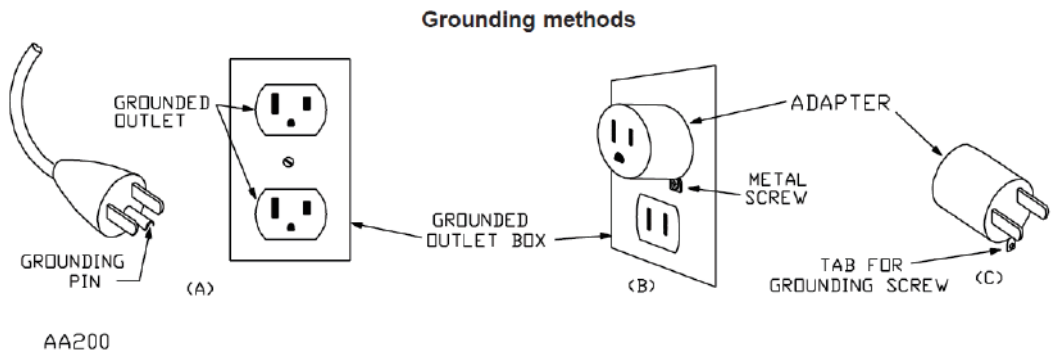

EARTHING

This massage chair is a Level One Electrical Appliance. To guarantee the ground wire that is connected to the power supply socket has obtained good ground connection, make sure to use a three-core power supply socket to avoid leakage, electric shock or other negative effects during use.

※ This product is designed for personal in-home use. Commercial use will void warranty.

Safety Precautions

- ※ The descriptions below are to use the product safely and accurately to prevent any unexpected risk or damage. Please follow the descriptions.
- ※ The safety precautions have two categories below depending on the expected risk and damage, and urgency if used incorrectly:

 **Warning** To reduce the risk of any burn, fire, electric shock, or physical damage

 **Caution** To reduce the risk of physical damage

Instructions Before Use

Warning

Do not install in bathrooms or areas with high humidity. It could result in electric shock.

It may cause electric shock, fire, product deformation, mold, or malfunction.

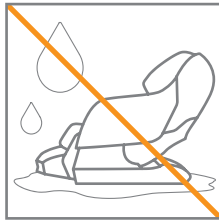

Avoid using in areas with dust or areas prone to rust.

It may cause electric shock, fire, product deformation, mold, or malfunction.



Do not operate in settings with temperatures exceeding 104F°.

It may cause fire or malfunction.

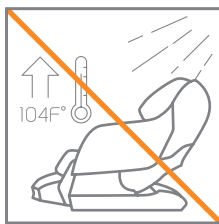

Do not install it outdoors.

It may cause safety accidents, physical damage, injury, product damage, or malfunction.

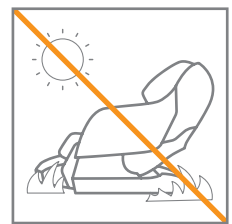

Do not use near heaters or anything that radiates heat.

It may cause product damage, fire, or malfunction.

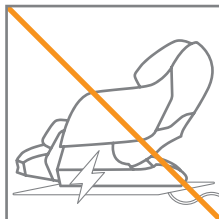

Install and use only on a flat, stable surface.

It may cause safety accidents, physical damage, injury, product damage, or malfunction.

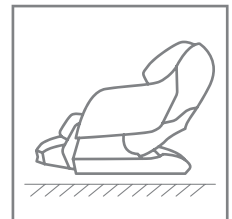

Safety Precautions

Instructions Before Use

Warning

Use in areas with ample space and reasonable air circulation.

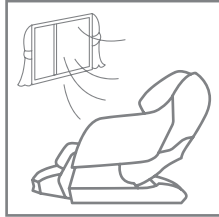

It may cause product deformation, mold, or malfunction.

Do not disassemble parts.



It may cause safety accidents, physical damage, injury, product damage, or malfunction.

Do not use concurrently with other electronic or medical devices.



It may cause safety accidents, physical damage, injury, product damage, or malfunction.

Do not spill or pour any foreign substances on the product.



It may cause product deformation, damage, safety accidents, or physical damage.

Do not place heavy objects on this product.

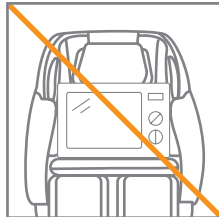

It may cause safety accidents, physical damage, product damage, or malfunction.

Please take precautionary measures to ensure toddlers and pets do not crawl under or on the back of the chair's body, leg rest, etc.

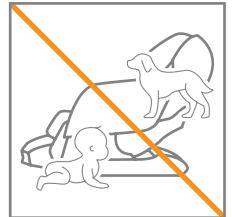

It may cause safety accidents, physical damage, injury, product damage, or malfunction.

Caution

Do not install or repair without the assistance of technicians.



It may cause safety accidents, physical damage, product damage, or malfunction.

Do not use the product for purposes other than what is stated in this Manual.



It may cause safety accidents, physical damage, product damage, or malfunction.

Safety Precautions

Instructions Before Use

Caution

Do not move the product through its power cord and pull the power cord.

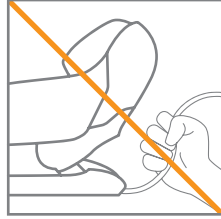

It may cause electric shock, fire, or malfunction.

Connect the product only to the grounded power outlet to avoid any risk of electric shock.

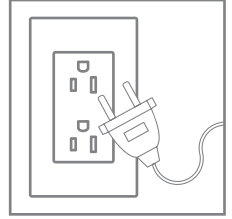

It may cause electric shock or injury.

Check if the product is connected to power before use.

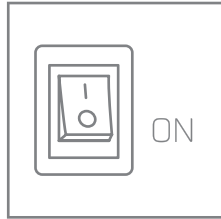

It helps proper use of the product.

Plug device into a 220-240V~ power outlet only.

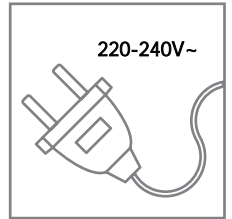

It may cause electric shock in case of malfunction or electric leakage.

Do not install in settings that are difficult to plug out.

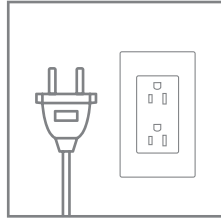

It may cause safety accidents, physical damage, product damage, or malfunction.

When unplugging the power plug, do not pull the power cable. Always pull the power plug instead.

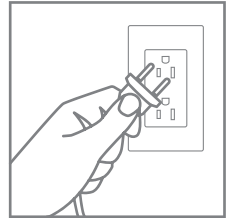

It may cause electric shock, fire, or malfunction.

Use the massage chair after checking safety sensors and if any children or pets are around.

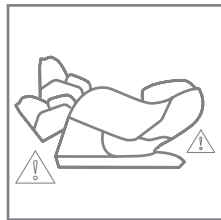

It may cause safety accidents, physical damage, product damage, or malfunction.

Please note the seat may become discolored when using the massage chair wearing dark-colored clothes, including jeans.

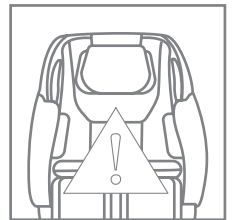

It may cause sheet discoloration.

Safety Precautions

Instructions Before Use

Warning

Please check how to operate the massage chair and the possible side effects.

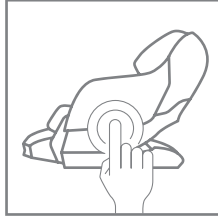

It helps properly use the product.

Do not connect or disconnect the power cord with wet hands. It may cause an electric shock.

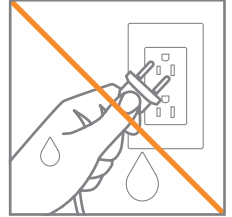

It may cause electric shock, fire, or malfunction.

Do not use the massage chair if your body is wet.



It may cause electric shock, fire, or malfunction.

Do not use the massage chair right after a heavy meal.

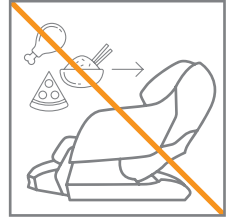

It may cause physical damage.

Be cautious not to let any body parts get caught during usage.

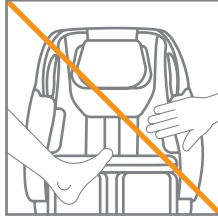

It may cause safety accidents, physical damage, product damage, or malfunction.

Be cautious not to focus on a certain body part too long. It may be an excessive burden.

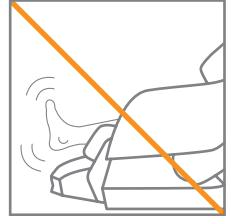

It may cause safety accidents, physical damage, product damage, or malfunction.

Disconnect the power plug from the outlet when the massage chair is not in use.

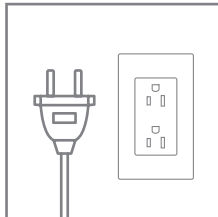

It may cause electric shock in case of malfunction or electric leakage.

Avoid using the massage chair for toddlers or babies.

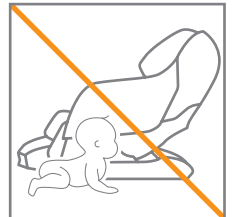

It may cause safety accidents, physical damage, injury, product damage, or malfunction.

Do not use the massage chair other than the accepted body parts, such as the head, elbow, knee, chest, or belly.

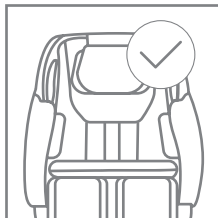

It may cause safety accidents, physical damage, product damage, or malfunction.

Please control the massage balls to ensure they are being operated in the right position.

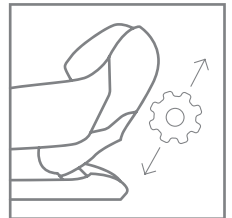

It may cause safety accidents, physical damage, product damage, or malfunction.

Safety Precautions

Instructions Before Use

Warning

After use, please wait until the reclining unit returns to its original position.



It may cause safety accidents, physical damage, product damage, or malfunction.

Stop using immediately if you experience any pain or discomfort and take appropriate measures for your health conditions.

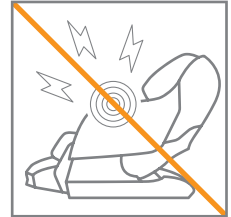

It may cause physical damage.

Consecutive usage may burden the individual's body. Select whether to use it consecutively according to user's health conditions.

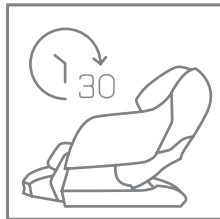

It may cause physical damage.

Prevent children or pets from playing around the massage chair during the operation.

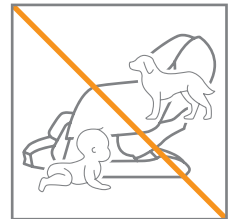

It may cause safety accidents, physical damage, product damage, or malfunction.

Do not operate the massage chair where aerosol (spray) products or oxygen is used.



It may cause product damage, fire, explosion or malfunction.

Do not operate the massage chair when wearing accessories.

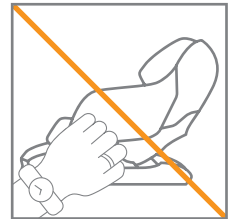

It may cause safety accidents, physical damage, injury, product damage, or malfunction.

Do not let long hair get caught in the massage chair.

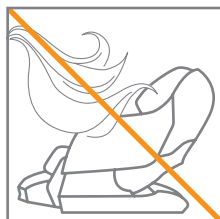

It may cause safety accidents and physical damage.

Do not drop personal effects or insert any object in the empty space.

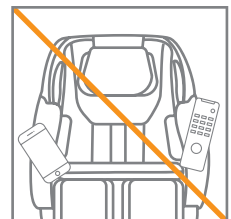

It may cause safety accidents, physical damage, product damage, fire, or malfunction.

If the cord or plug malfunctions, is damaged, or soaked in water, do not operate the massage chair and contact Customer Service Center.

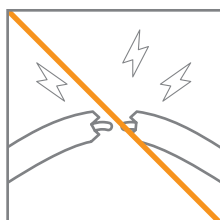

It may cause electric shock, fire, or malfunction.

Be aware not to burn when using the heating feature.



It may cause a low-temperature burn.

Safety Precautions

Instructions Before Use

Warning

Sit in the massage chair in appropriate position.

It may cause safety accidents, physical damage, injury, product damage, or malfunction.

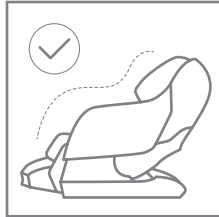

Do not use the massage chair when the cover is torn or removed.

It may cause safety accidents, physical damage, product damage, or malfunction.

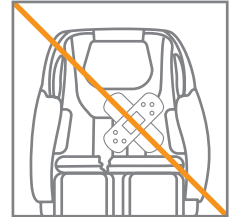

Caution

No more than one person may operate the massage chair at a time.

It may cause safety accidents, physical damage, product damage, or malfunction.



Avoid using the massage chair when the temperature changes significantly.

It may cause physical damage or injury.

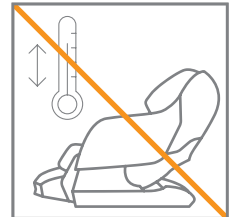

Do not apply more than 264 lbs pressure on the product.

It may cause safety accidents, deformation, noises, wear of leather, or malfunction.



People shorter than 5' or taller than 6'3" may feel different when massaging.

It may cause a lack of tightness between massage units and body parts, pain, or physical damage.



Do not stand on the massage chair. Please use it in the sitting position.

It may cause safety accidents, physical damage, injury, product damage, or malfunction.



Be aware of hypothermia after using the massage chair when the individual falls asleep.

It may cause safety accidents, physical damage, etc.

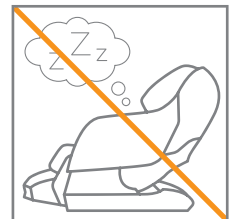

Safety Precautions

Instructions Before Use

Caution

Be aware the cord is not damaged or excessively bent.

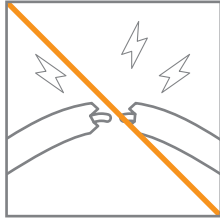

It may cause electric shock, fire, or malfunction.

Please start at the lower intensity for safe use.



It may cause physical damage.

Do not hold the leg rest unit with your hands.

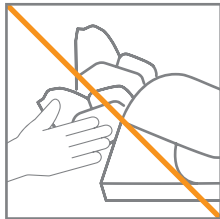

It may cause safety accidents, physical damage, product damage, or malfunction.

Do not lean or hang on the back side of the massage chair.



It may cause safety accidents, physical damage, product damage, or malfunction.

Prevent pets from biting the power cord.

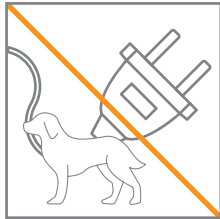

It may cause electric shock, product damage, or malfunction.

Do not stand on the leg rest when the massage chair is tilting.



It may cause safety accidents, physical damage, product damage, or malfunction.

Please ensure the power is off before connecting the power.

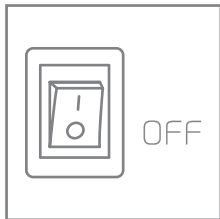

It may cause electric shock, product damage, or malfunction.

Do not sit on the back of the massage chair, arm massage unit, or leg massage unit.



It may cause safety accidents, physical damage, product damage, or malfunction.

Store the controller at the given position and do not pull or hit it.

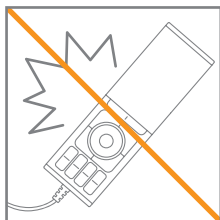

It may cause safety accidents, physical damage, product damage, or malfunction.

Do not forcefully press the controller buttons.

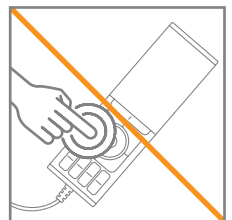

It may cause safety accidents, physical damage, product damage, or malfunction.

Safety Precautions

Instructions Before Use

Caution

Do not use the Bluetooth too loud and too long. (*Applies to some massage chairs)

It may damage your hearing ability.

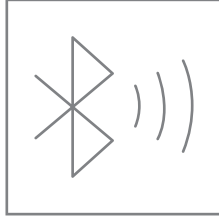

Do not stand up while holding the tablet holder with your hands. (*Applies to some massage chairs)

It may cause safety accidents, physical damage, product damage, or malfunction.



Do not wash the massage chair.

It may cause electric shock, fire, or malfunction.



Please disconnect the power while cleaning or organizing the massage chair.

It may cause safety accidents, physical damage, product damage, or malfunction.

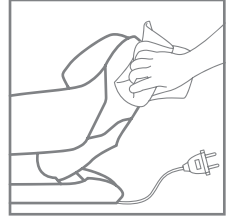

Gently remove dirt with soft cloth and do not use organic solvents, including thinner or chemicals.

It may cause product damage.

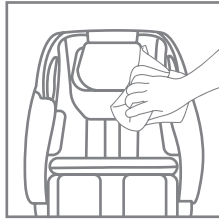

Use the dedicated leather cleaner when cleaning the natural leather sheets. (*Applies to some massage chairs)

It may cause product damage.

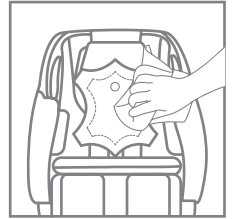

Use the sealed cable when charging via the USB charging port. (*Applies to some massage chairs)

It may cause electric shock, fire, or malfunction.

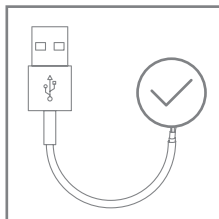

※ Sealed cable means a protected cord covered with aluminum foil or copper or steel nets to reduce noises from the outside and inside.

Safety Precautions

Instructions Before Use

Precautions

- **Do not use the product if**
 - Doctor diagnoses to not use this massage chair for those who suffer from thrombosis, embolism, a serious varicose veins
 - Pregnant women in the first trimester or the beginning of the third pregnancy trimester
 - Those who suffer from severe diseases related to the heart, kidneys, or liver
 - Those who suffer from schizophrenia or other mental disorders
 - Those who suffer from uncontrollable epilepsy or other brain diseases
 - Those who cannot move by themselves
- **Before use, consult with a specialist if**
 - Pregnant women other than those who are within the first trimester and may experience side effects from the use
 - Those who have higher body temperature and suffer from acute inflammation, including chills and fever
 - Those who suffer from severe skin disease, including pressure sore or burn
 - Those who suffer from a malignant tumor
 - Those who are old, suffer from extreme weight loss or loss of muscle tissue due to other diseases
 - Those who need to stay in bed due to medical treatment
 - Those who are diagnosed with acute disc and acute cervical sprain
 - Those who suffer from severe osteoporosis
 - Those who are using implantable electronic medical devices, including implantable pacemaker
 - Those who lack communication ability
 - Those who have difficulty moving their body
 - Those who have any other health concerns
 - Those with joint discomfort due to hip or knee joint surgeries (artificial joint, fracture, etc.)

Instructions for Use Heating Feature

- If using the product long without rest, it may cause a low-temperature burn or any other risks.
- Do not let skin come in direct contact with parts of the massage chair that heat up.
- Supervise young children, seniors, and patients when they are using this product as they have sensitive skin.
- Do not fall asleep with the heating function on.

Possible Side Effects

- **Please note the following side effects, which may occur during use.**
 - Minor abrasions, bruising, etc.
 - Damage to muscle or tendon injury due to overuse or too much pressure
 - Allergic reactions and burns
 - Elderly spine fractures, dislocated joints, etc.

Components and Descriptions

Opening the box

This product is packaged in three boxes. Please check that you have received all the necessary parts.

- **Main Box:** Body, Back/Butt Sheet, Head Sheet, Shoulder Massage Units, Accessory Box (Controller, Power Cable, And User Manual)
- **Arm Unit Box**
- **Leg Unit Box**

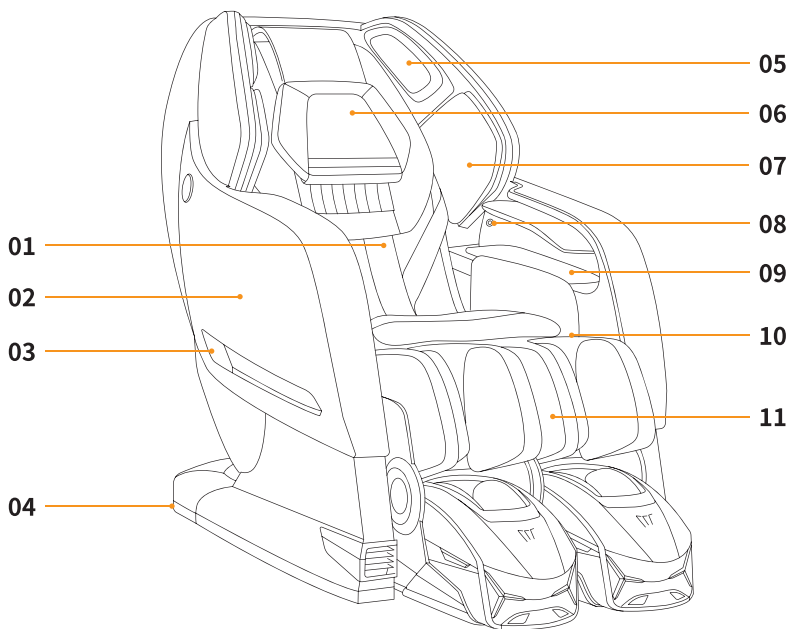

Exterior

- 01** Back/Butt Sheet
 - 02** Side Panel
 - 03** LED Lights
 - 04** Wheel for ease of movement
 - 05** Speaker
 - 06** Head Sheet
 - 07** Shoulder Massage Unit
 - 08** Blackout Protection Button
※ It will reset the massage chair to the original position in case of a power outage.
 - 09** Arm Massage Unit
 - 10** USB Charging Port
※ There is a black circular lid inside the left buttocks sheet. There is a USB charging port when opening the lid.
 - 11** Leg Massage Unit
-

Moving and Installation

Moving method and checking for leg room

- Before installation, check whether there is enough room for installation.
- Remove all obstructions or miscellaneous objects around the product.
- Do not install the product with its back facing a glass window.
- Recline the product until it is convenient enough to move, then move it to the desired location.
Install it by slowly putting it down.
- Be careful that the cables do not become stuck under the product during installation.

- ※ The weight of the product may cause damage or discoloration to the floor.
- ※ When moving the product, make sure more than two people carry it together.

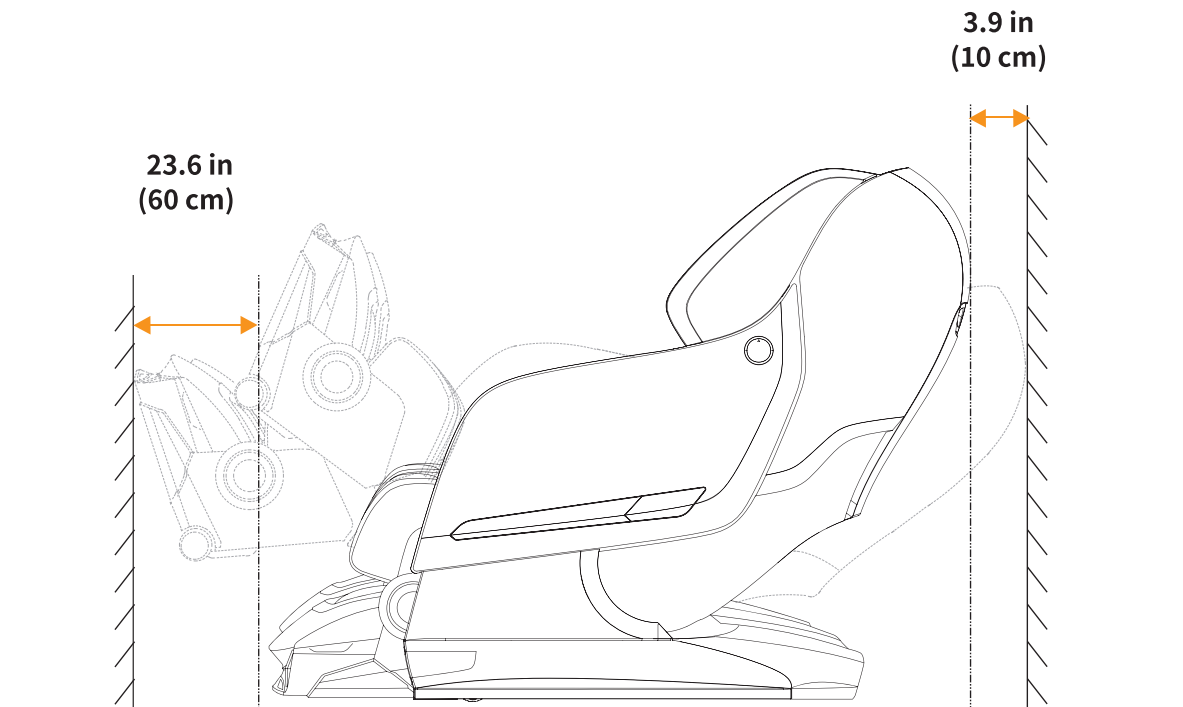

How to Connect the Product

Connecting the controller

Connect the controller cable with its port positioned on the inside of the right side panel.

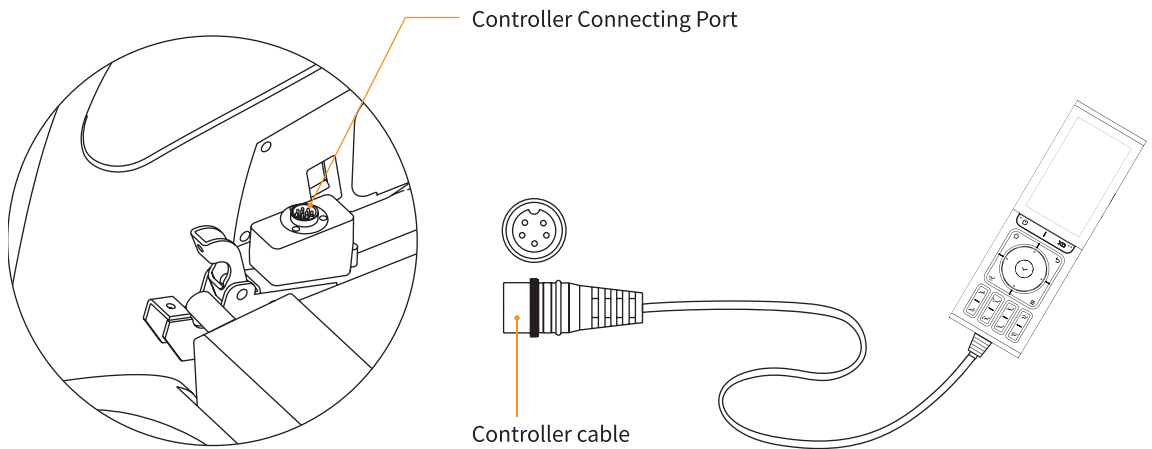

Connecting to power source

Connect the power cable to its port positioned on the lower-right region of the main body. After connecting, turn on the power switch.

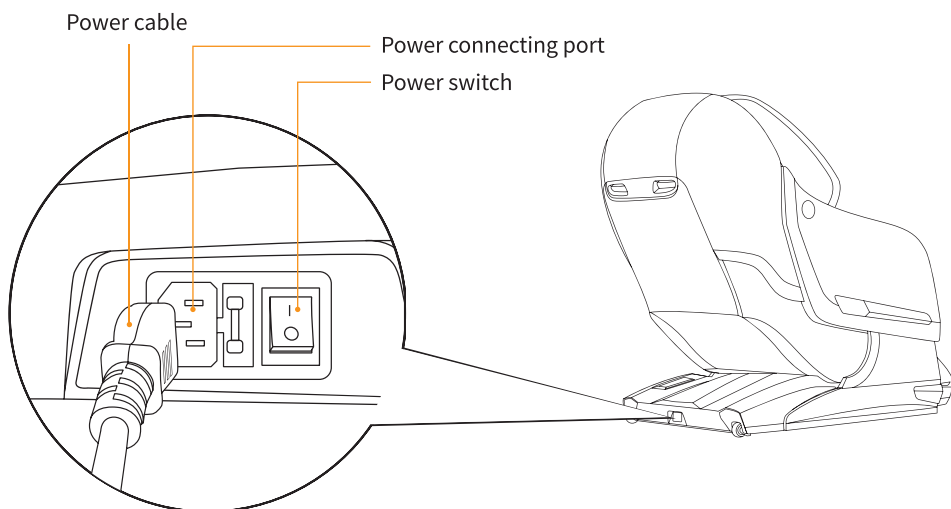

How to Connect Wi-Fi [Software Update]

Connecting to Wi-Fi

BODYFRIEND [Wi-Fi Connection Assistant] app enables the latest software updates without any service technician.

1. Check before connection

Check if the product and Wi-Fi router are connected to the power.

- ※ Check if the router supports 2.4GHz. (5 GHz not supported)
- ※ Check the SSID (router name) and password of the Wi-Fi router in use.

2. Install the app

Smartphone - Search for [Bodyfriend Wi-Fi Connection Helper] in Google Play Store or Apple App Store and download the app.

Complete the connection by following the instructions in the app.

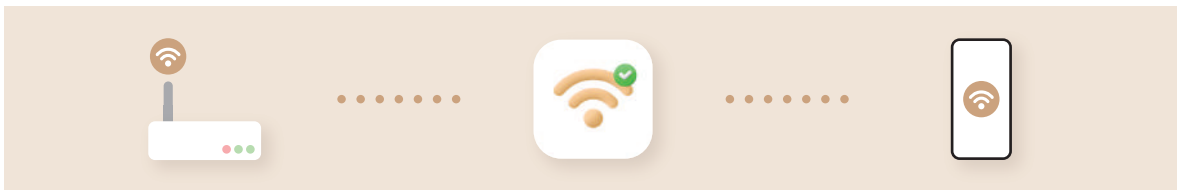

Notes

- 01** This BODYFRIEND product supports 2.4 GHz only. (5 GHz not supported)
- 02** Some smartphones may fail to connect to Wi-Fi due to their device settings.
- 03** The app is supported in Android OS ver. 5.0 or higher/iOS ver. 12.0 or higher.
- 04** Wi-Fi connection may fail due to an unstable network or firewall.
- 05** If you fail to connect to Wi-Fi after taking measures instructed by the Internet service provider, please contact our customer service.
- 06** Service features may vary due to product specifications and changes by the app updates without previous notice.



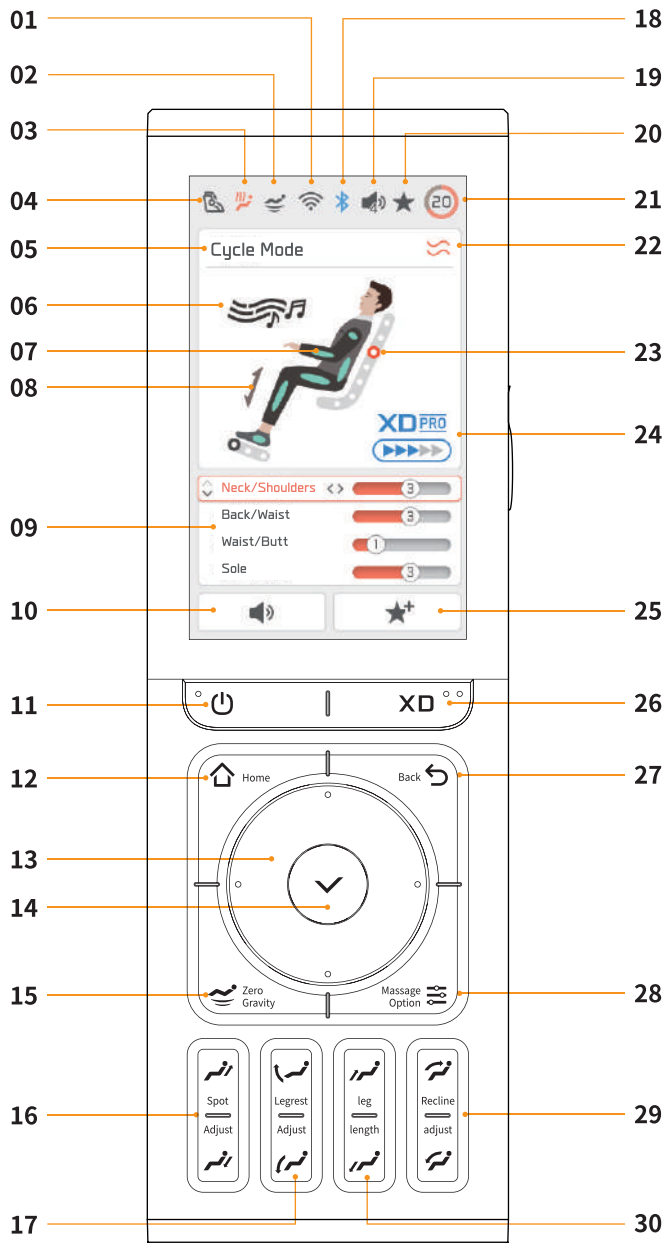



Controller Button Descriptions

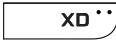
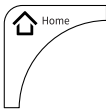
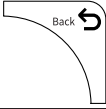
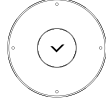
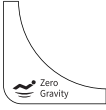

Controller Components

- 01 Wi-Fi Connectivity Indicator
- 02 Zero Gravity Indicator
- 03 Heating Indicator
- 04 Auto/Manual Program Indicator
- 05 Current Massage Mode Indicator
- 06 Music Playing Indicator
(Except for Bluetooth)
- 07 Airbag Indicator
- 08 Leg Length Adjust Indicator
- 09 Neck/Shoulders Massage Speed
Back/Waist Massage Speed
Waist/Butt Massage Speed
Sole Massage Speed
- 10 Volume Adjust (Go to Settings)
- 11 Power/Pause
- 12 Home Mode
- 13 Up/Down/Left/Right
- 14 OK
- 15 Zero Gravity Angle Settings
- 16 Spot Adjust
- 17 Legrest Adjust
- 18 Bluetooth Connectivity
- 19 Volume Intensity Level
- 20 Favorites
- 21 Message Time
- 22 Message Technique
- 23 Message Module Position
- 24 XD Intensity Level
- 25 Add to Favorites
- 26 XD Intensity Level Settings
- 27 Back
- 28 Message Option
- 29 Recline Adjust
- 30 Leg Length

Controller Button Descriptions

	Power/ Pause	<p>Power: If the [Power button] is pressed during operation, check the guide screen, and choose Yes. All movement will stop and all massage balls and parts of the massage chair will return to their original position.</p> <p>Pause: If [Power button] is pressed during operation, the massage chair will pause. When you check the guide screen and select No, the massage will resume.</p> <p>※ [●] Braille: Braille is indicated for the visually impaired.</p>
	XD Intensity Levels	<p>You can customize the range for the roller heads to protrude along the contours of your body.</p> <p>※ [●●] Braille: Braille is indicated for the visually impaired.</p>
	Home	If the [Home button] is pressed, it will lead to the Home screen.
	Previous	Go to the previous screen.
	Up/Down/ Left/Right, OK	<p>Move and select by [Up/Down/Left/Right button] and run by [OK button]. In the massage screen, select the desired massage part using the [Up/Down button], and adjust the massage speed levels using the [Left/Right button].</p>
	Zero Gravity	This button will transit the body into the zero-gravity position, which is an ideal posture for massages.
	Massage Option	Controls roller, heating, and airbag intensity levels.
	Spot Adjust	<p>Checks the contour of your body and adjusts the shoulder unit position. When selecting an auto program, you can adjust the shoulder unit position. When selecting a manual mode, you can adjust the up/down position of the massage balls.</p>
	Legrest Adjust	<p>This button adjusts the leg angle. You can adjust the individual left/right leg massage units.</p> <p>※ In some modes, you can manually change the angle after the indication of auto leg adjust is off pops up.</p> <p>※ When the leg angle changes, the leg length will be measured again. For accurate measurement, put the heel deep inside the leg units.</p>
	Leg Length	<p>Adjusts the leg length. You can adjust the individual left/right leg massage units.</p> <p>※ In some mode, you can manually change the length after indication of auto leg adjust is off pops up.</p>
	Recline Adjust	<p>This button adjusts the reclining angle.</p> <p>※ In some modes, you can manually change the angle after the indication of auto leg adjust is off pops up.</p>

Controller Operation Descriptions

Start

[Power button] > Select the desired mode and press the [OK button] > Check the contour of your body and adjust the shoulder unit position > Start massage

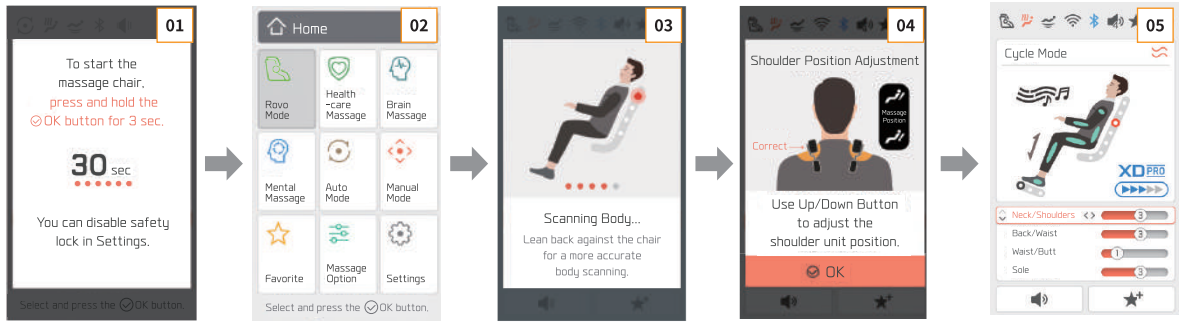

01 Safety Lock

We provide a safety lock feature for safety. This feature prevents children from operating the massage chair unsupervised. Turn on the controller and the safety lock screen will appear. Press and hold the [OK button] for more than 3 seconds to turn off the lock and use the massage chair. You can decide whether to use this feature on the Settings menu.

02 Home Mode

This will pop up when pressing the [Home button]. Users can select their desired program and other massage chair feature details.

03 Checking for the Contour of User's Body

When the massage starts, the chair will automatically check and set up for the contour of your body. Please keep your back straight while checking for the contour.

04 Adjust Shoulder Unit Position

After checking the contour, the Adjust Shoulder Unit Position screen will appear. Press the [Spot Adjust button] to change position and press the [OK button].

※ When pressing the [OK button], the massage will start immediately. When not pressed, massage will automatically start 10 seconds later.

05 Massage Status Screen

This screen shows the status and time of the current massage. Select the desired massage location using the [Up/Down button] and adjust the massage speed using the [Left/Right button].

Finish

[Power button] > Check the guide screen and select Yes > Massage ends

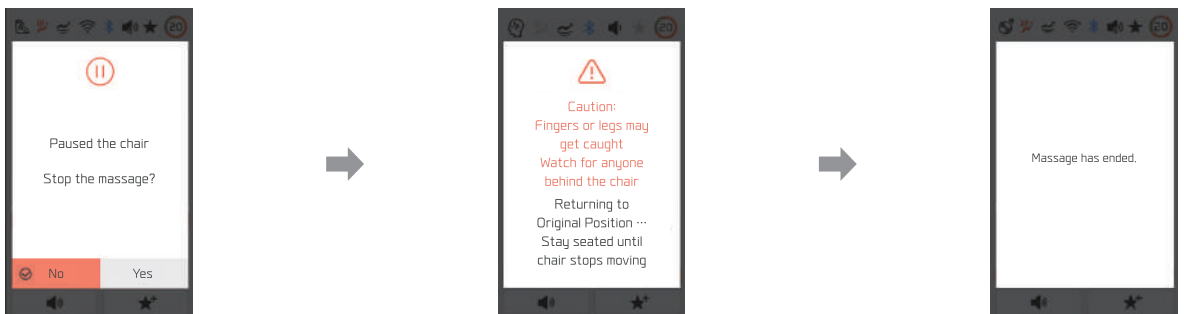

Controller Operation Descriptions

Separately-moving leg massage unit by left/right

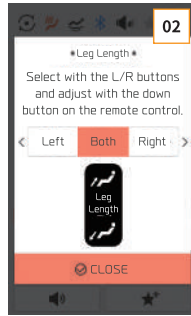
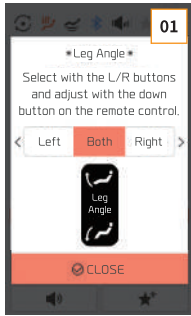

01 Adjust Leg Angle

[Legrest Adjust button] > Select left, right, or both by pressing the [Left/Right button] > Adjust the angle by using the [Legrest Adjust button] or [Up/Down button] > [OK button]

02 Adjust Leg Length

[Leg Length button] > Select left, right, or both by pressing the [Left/Right button] > Adjust the length of each unit by using the [Leg Length button] or [Up/Down button] > [OK button]

Object detection notice

Object detection guide screen > Remove the object and press the [OK button] > Resume massage

※ If the product continues to show the Object Detection screen after removing the object, press and hold the [OK button] to return to its original position.

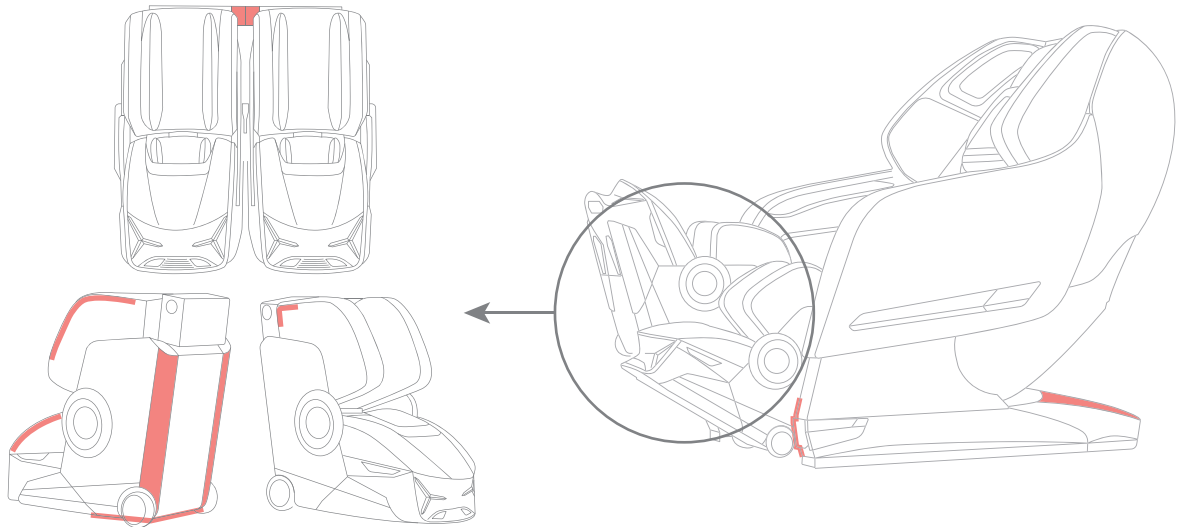

※ Object detection sensors are positioned at a total of 15 places at the leg units and back of the massage chair.

Controller Operation Descriptions

Adjust shoulder unit position

Auto Program (Rovo Mode, Healthcare/Brain/Mental Massage, Auto Mode)

01 When pressing the [Spot Adjust button] in the lower region of the controller during the auto program, the current massage and song will be paused and guide screen for re-adjusting shoulder unit position will appear.

02 Adjust the shoulder unit position by the [Spot Adjust button] or [Up/Down button], press [OK button], and the massage will resume.

※ Manual Mode has a separate Message Spot - Fixed menu.

During the massage for each body part, pressing the [Spot Adjust button] will not fix the massage spot.

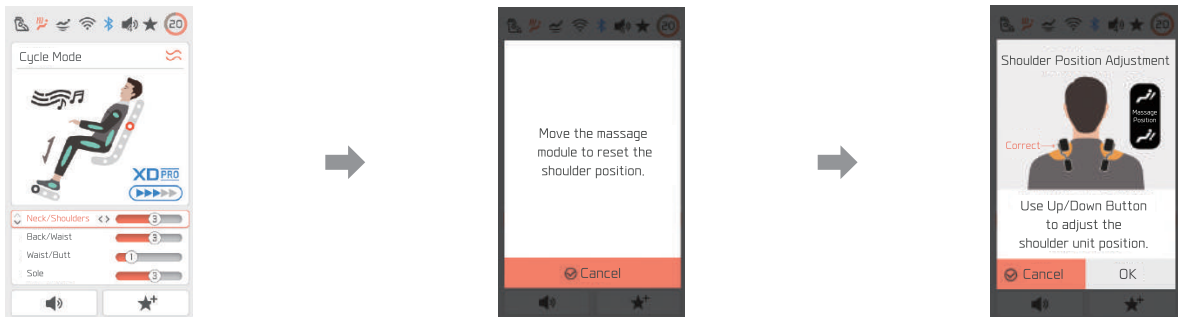

Quick ON/OFF by each body part

Quick ON/OFF for each body part sets up each Airbag and Roller features for each body part in the Massage Status screen. It adds additional massage for each body part.

[How to Operate]

01 Massage Status screen > Go to the human image at the top by using the [Up/Down button] and select the desired body part among Lower Body/Arms/Shoulders/Body.

02 Select the desired body part and turn on/off the Airbag or Roller features.

※ Arms/Shoulders/Body only allows turning airbags on/off.



Controller Operation Descriptions

Rovo Mode

Home > Rovo Mode > Select the desired mode and press the [OK button] > Check the contours of your body and adjust the shoulder unit position > Start massage

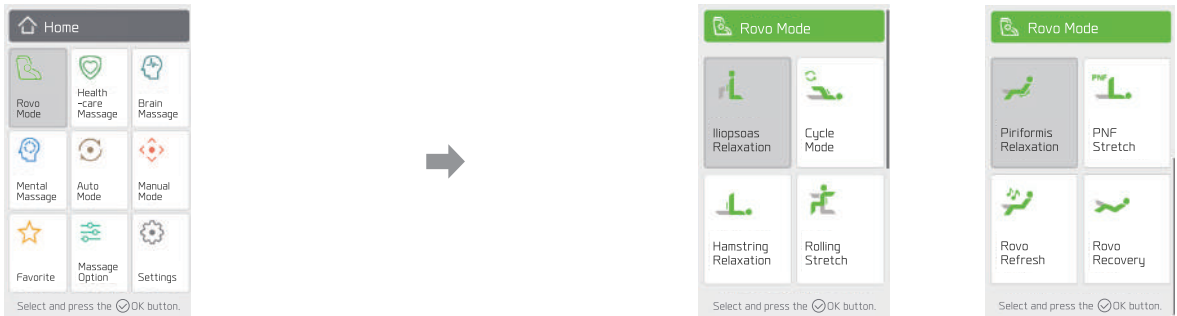

Healthcare Massage

Home > Healthcare Massage > Select the desired mode and press the [OK button] > Check the contours of your body and adjust the shoulder unit position > Start massage



Brain Massage

Home > Brain Massage > Select the desired mode and press the [OK button] > Checking for the contours of your body and adjust the shoulder unit position > Start massage



Controller Operation Descriptions

Mental Massage

Home > Mental Massage > Select the desired mode and press the [OK button] > Check the contours of your body and adjust the shoulder unit position > Start massage



Auto Mode

Home > Auto Mode > Select among the desired Body Part/Stretch/Sleep/User/Sports and press the [OK button] > Select the mode and press the [OK button] > Check the contours of your body and adjust the shoulder unit location > Start massage

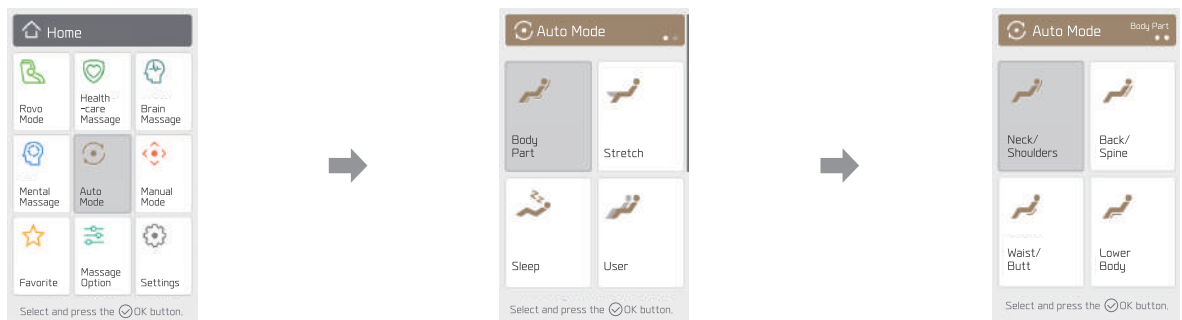

Manual Mode

Home > Manual Mode > Select Message Spot > Select Massage Technique > Adjust details level and press the [OK button] > Select the airbag position and intensity Adjust among 0-5 levels > Press the [OK button] > Massage starts

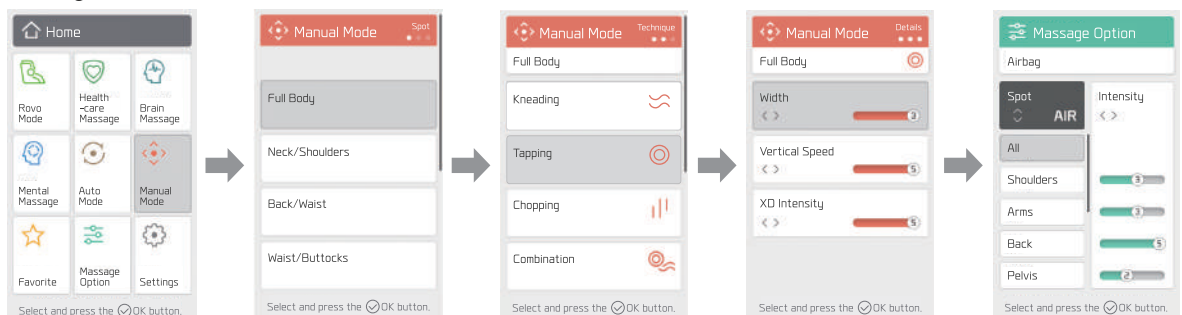

Controller Operation Descriptions

Favorite

- 01** Registration: Run the desired mode > Custom Message settings > Register as a Favorite.
- 02** Run: Home > Favorite > List > Select the desired mode among the favorite > press the [OK button]
- 03** Manage the list: Users can register up to 8 Favorite. Users can remove unnecessary modes on “Favorite - Manage”.

※ When the Favorite mode changes, it is registered as a new Favorite mode.

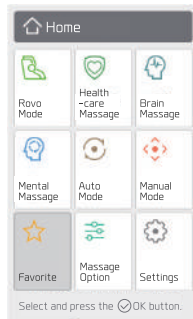

[Favorite Save History Range]

Auto Program

- 01** Select Mode
- 02** Message Speed for Each Body Part
- 03** Message Position
- 04** XD PRO Intensity
- 05** Airbag Intensity for Each Body Part
- 06** Music

Manual Mode

- 01** Message Spot
- 02** Message Technique
- 03** Message Width
- 04** Vertical Speed
- 05** XD PRO Intensity
- 06** Message Position
- 07** Back Unit Angle & Position
- 08** Leg Angle & Position
- 09** Airbag Intensity for Each Body Part

Roller

Home > Message Option > Roller > Adjust the speed among 0-5 levels

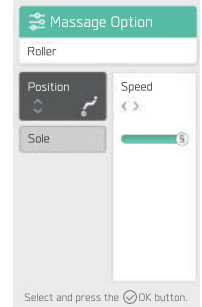
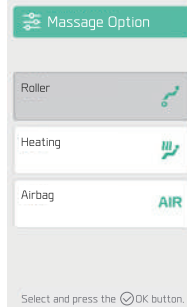
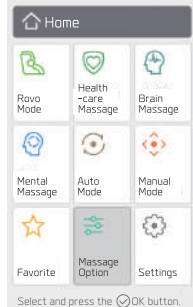

Heating

Home > Message Option > Heating > Select the location and adjust the intensity among 0-3 levels

※ Heating is limited to where heating wires are applied.

※ To prevent low-temperature burns, after 20 minutes of Level 3 heating intensity, it is automatically reduced to Level 2.

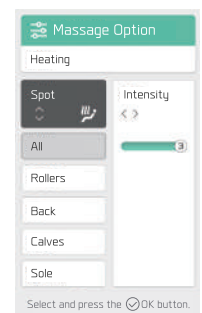
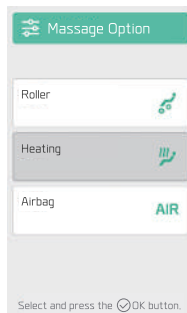
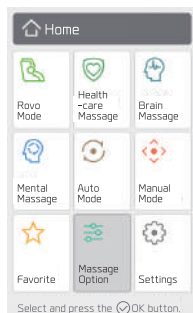

Controller Operation Descriptions

Airbag

Home > Massage Option > Airbag > Select the location and adjust the intensity among 0-5 levels

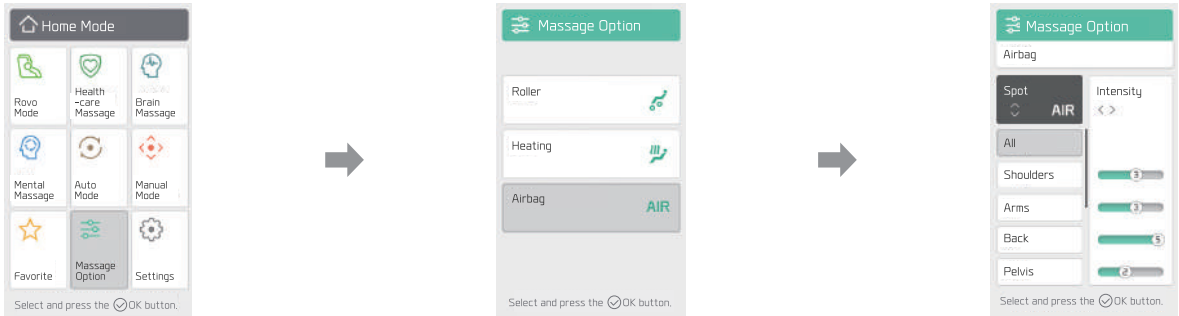

Change message time

Home > Settings > Select the message time among 10/20/30 minutes

※ Message time cannot be adjusted for Rovo Mode - PNF Stretch, Brain Massage, Mental Massage and Auto Mode - Natural Sleep, Nap, and Hammock Nap.

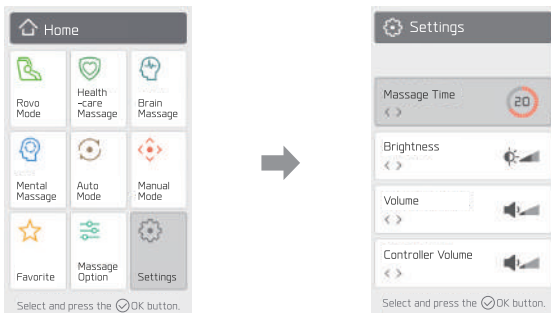

Screen brightness

Home > Settings > Select the screen brightness among 0-5 levels

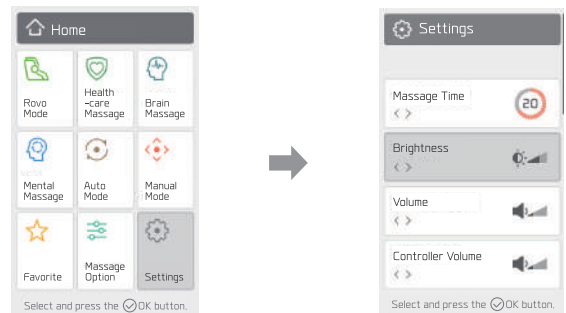

Massage Chair Volume

Home > Settings > Select the volume among 0-10 levels

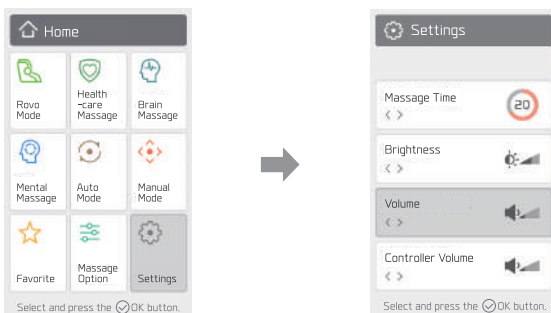

Controller Volume

Home > Settings > Select the volume among 0-3 levels

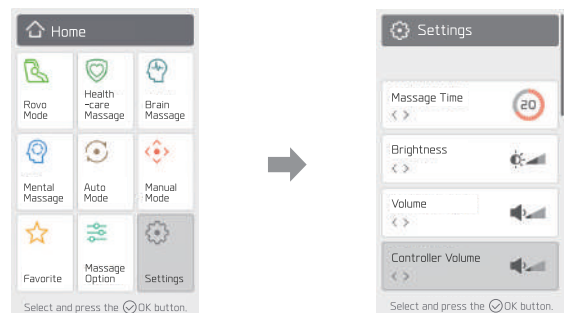

Controller Operation Descriptions

LED

Home > Settings > Select Side Panel LED Lights ON/OFF

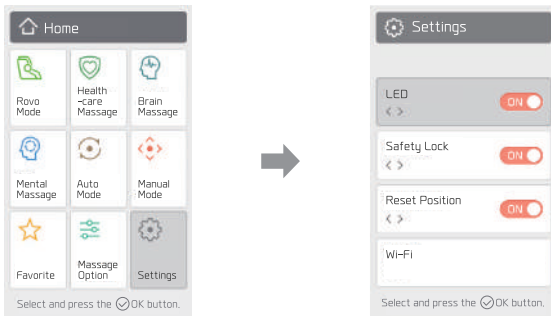

Safety Lock

Home > Settings > Select Safety Lock ON/OFF

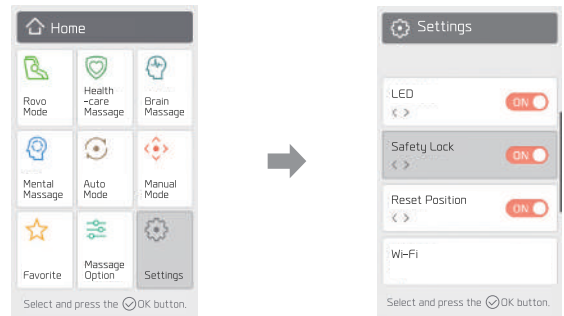

Reset Position

Home > Settings > Select Automatically Return to Original Position On/Off

※ Allows the massage chair to returns to its original position automatically.

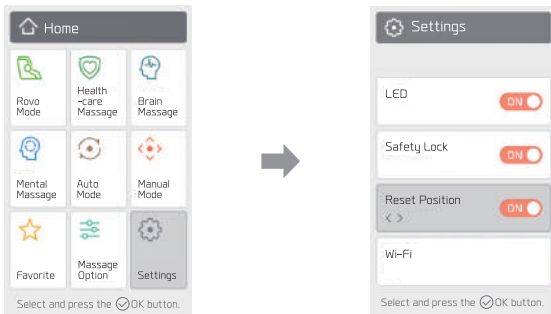

Wi-Fi

Home > Settings > Wi-Fi > Select Wi-Fi > Select On/Off

※ Please select ON for the Wi-Fi settings to update to the latest software.

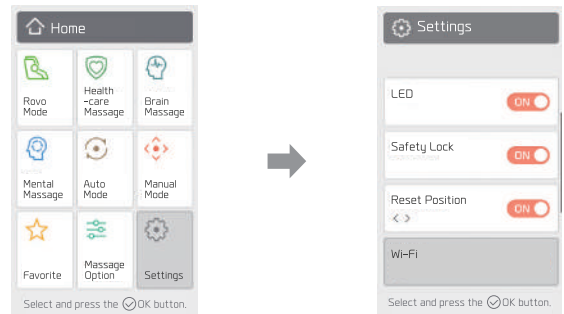

Controller Operation Descriptions

Bluetooth

Home > Settings > Bluetooth > Bluetooth On/Off

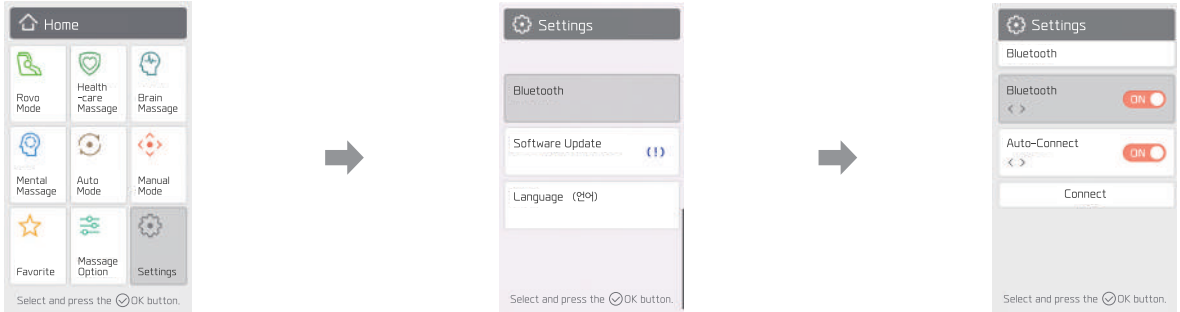

※ How to Set up Bluetooth

01 Home > Settings > Select Bluetooth

02 Select Bluetooth ON > Select Connect and [OK button]

※ When auto-connect is ON and the message chair turns on, it will automatically connect to the last-connected device.

03 Mobile devices - Activate Bluetooth Connection > Find Bluetooth Devices > Connect Phantom Rovo

※ Name: PHANTOM-ROVO-####

(#### is a unique Bluetooth number of the product. If there are various message chairs in one area, please check the serial number before connecting.)

Software Update

Home > Settings > Software Update

※ Please select ON for the Wi-Fi settings to update to the latest software.

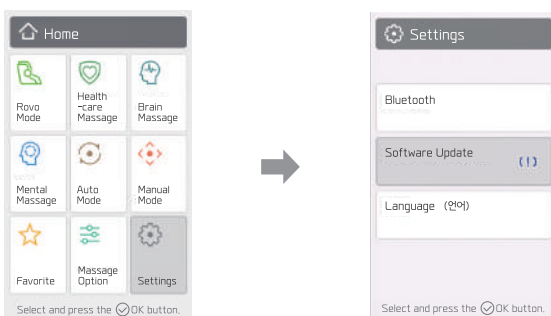

Language

Home > Settings > Language > Select Language > [OK button]

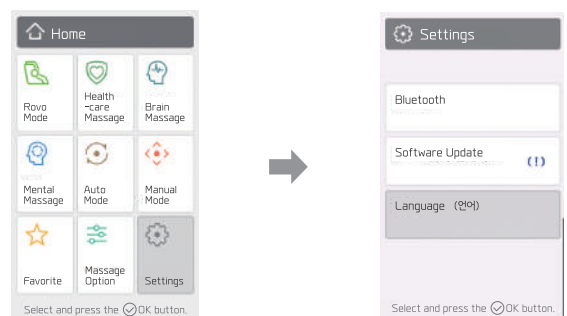

Rovo Mode · Healthcare Massage

Rovo Mode

Home > Rovo Mode > Select the desired mode and press the [OK button] > Check the contours of your body and adjust the shoulder unit position > Start massage

Iliopsoas Relaxation	Relaxes the core muscles with static stretches.
Cycle Mode	Boosts the flexibility of the lower body by relaxing muscles around the knees and hip joints with cycling movement.
Hamstrings Relaxation	Boosts flexibility by stretching muscles on the back of the thighs.
Rolling Stretch	Boosts flexibility of muscles around the waist.
Piriformis Relaxation	Boosts flexibility by relaxing muscles on the back of the buttocks.
PNF Stretch	Combines the relaxation of muscles in the lower body and muscle exercises concurrently.
Rovo Refresh	Kneads and applies acupressure to the areas where fatigue is built up, providing vitality and energy.
Rovo Recovery	Boosts the flexibility of the legs by gently applying acupressure focused on the neck and waist.

Healthcare Massage

Home > Healthcare Massage > Select the desired mode and press the [OK button] > Check the contours of your body and adjust the shoulder unit position > Start massage

Swelling Relief	Helps blood circulation and reduces swelling by using full-body airbags.
Hangover Relief	Massages the key acupuncture points for a hangover cure.
Suboccipital Release	Relaxes and focuses on four muscles attached to the occipital bone and back of the neck.
Perineal Massage	Focuses on the perineal area by applying acupressure on the perineal area and kneading the buttocks through airbags.

Brain Massage · Mental Massage

Brain Massage

Home > Brain Massage > Select the desired mode and press the [OK button] > Checking for the contours of your body and adjust the shoulder unit position > Start massage

Imagery Massage	This course is for those who want to freely imagine their own getaway with XD mental imagery sound.
Focus	This course is for those who need to rest their fatigued brain due to excessive academic or work stress and recharge their mind and body.
Well-Being	This course is for those who need a break due to excessive stress from their daily life.
Relaxation Training	This course is developed by using gradual muscle relaxation therapy for those who want to reduce tensions and stress in their mind and body. ※ Gradual muscle relaxation therapy: Intentionally reduces the bodily tension of muscles to remove the tension of the mind.
Breathing Relaxation	Developed by breathing relaxation therapy for those expecting important tests or announcements. ※ Breathing relaxation therapy: Intentionally adjusts breathing to relax the mind and reduces excessive tension and excitement
Good morning	Specializes in those who are not early birds and have difficulty pleasantly starting the day.
Good night	Specialized for those who want to reduce fatigue during the day and organize their thoughts before going to bed.

Mental Massage

Home > Mental Massage > Select the desired mode and press the [OK button] > Check the contours of your body and adjust the shoulder unit position > Start massage

Mind Comfort	Helps those who are gloomy due to past regrets.
Hope	Helps those who suffer from anxiety and nervousness due to various concerns.
Self-esteem	Helps comfort your mind and recover self-esteem when feeling down and frustrated.
Gratitude	Helps remind us of the precious things in our daily lives and refreshes our mind.
Forgiveness	Suggests active forgiveness and comfort for yourself with calming music.
Trauma	Provides a stable mind for those who suffer from past memories.
Love	Suggests a way to love yourself via massage and breadth of mind.
Passion	Suggests to embrace the GRIT that exists in your mind during the massage.

Auto Mode

Auto Mode

Home > Auto Mode > Select among the desired Body Part/Stretch/Sleep/User/Sports and press the [OK button] > Select the mode and press the [OK button] > Check the contours of your body and adjust the shoulder unit location > Start massage

Body Part	Neck/Shoulders	Relaxes neck and shoulders via rubdown and stretches.
	Back/Spine	Relaxes back and spine via acupressure and rubdown.
	Waist/Butt	Relaxes waist and buttocks areas via acupressure and rubdown.
	Lower Body	Provides various massages focused on the waist and leg areas.
Stretch	Legs-Hip Stretch	Strongly stretches the lower body by supporting the pelvis and pulling the legs.
	Spine Stretch	Strongly stretches the spine by supporting the back of the head and pulling the legs with spine area massage.
	Slow Stretch	Provides soft stretching and relaxation for those who want to avoid strong stretching.
	Airbag Stretch	Relaxes and provides soft massage with airbags.
Sleep	Natural Sleep	Induces sleep via soft and simple full-body massage and angle variation for 30 minutes.
	Nap	Induces an effective nap of less than 20 minutes by repeating soft tapping.
	Hammock Nap	Provides comfortable massage like sleeping in the hammock via swing patterns.
	Soft Sound	Provides a full-body rubdown course without airbags and is ideal for use at night when everyone is sensitive to noise.
User	CEO Mode	Focuses on neck and shoulders to reduce CEO's fatigue burdened by excessive stress.
	Senior Mode	Provides safe massage for seniors who prefer soft and mild massage.
	New Parent	Focused on the neck and waist that are fatigued by parenting and applies special airbag patterns massage on arms, legs, and pelvic areas.
	Office Mode	Provides refreshing massage on the waist, neck, and shoulders of students who sit in a chair all day long.
Sports	Golf Mode	Provides strong massage on arms, legs, and soles fatigued after golf.
	Pilates Mode	Helps keep the right posture to stimulate core muscles on the buttocks and lower belly and relax muscles by reclining the chair on a full-body and leg angle.
	Yoga Mode	Provides a dynamic massage and stretch using yoga movements for a flexible body.
	Driving Mode	A soft massage focused on the tired upper body after a long drive.

XD PRO Module Description

BODYFRIEND's exclusive new XD massage system

1. Wide and Deep XD Massage

- Provides a rubdown massage for a wider area using the long axis of rotation of the XD module.
- Massage balls provide a sophisticated and deep massage while drawing an X pattern.

2. Ergonomic XD Massage Angle

- Adjust the angle depending on the massage technique for a more focused massage on body parts.
- Provide strong massage for big muscles and gentle massage for small muscles.
- Realize similar angles of massage conducted by a real massage therapist.

XD PRO

Customized Massage System by Analyzing User's Body Contour

1. Quick and Accurate Body Contour Recognition

- Massage modules drop along the contour of the body to recognize the accurate location of shoulders by sensing curves and pressures of the human body.
- Even during the massage mode, you can adjust the shoulder position in real time.

2. Sophisticated and Gentle Massage

- High performance sensors provide more sophisticated massage than the previous XD module.
- Precise body contour recognition enables various massage techniques.

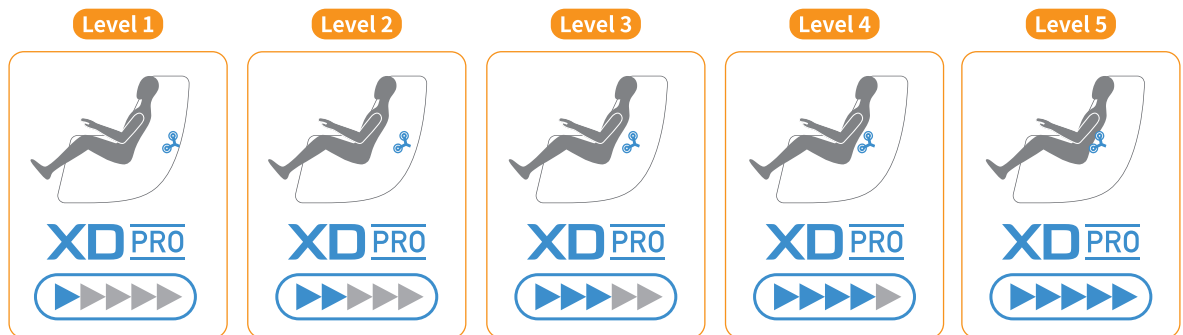

Product Size and Specifications

For performance improvement, the specification may partially change without previous notice.

Model	AP9091
Reclining Angle	130~170° (Motorized with no level)
Lower Body Angle	0~70° (Motorized with no level)
Rubdown	17~23 kneads per minute
Rubdown Width	1.8~7.9 in (4.5~20cm)
Tapping	470~665 taps per minute
Power Supply	220-240V~
Rated Current	1.5 A
Rated Frequency	50-60Hz
Auto timer	10/20/30 minutes
Airbags	Shoulders/Arms/Back/Pelvis/Thighs/Perineum/Calves/Top Of Feet/Heels
Rollers	Soles
Massage Spot	Neck - buttocks
Product Weight	352 lbs (159.7 kg)
Dimensions Reclined	78.7 in (Length) X 33.5 in (Width) X 39 in (Height) (200 cm x 85 cm x 99 cm)
Dimensions Upright	64 in (Length) X 33.5 in (Width) X 47.2 in (Height) (163 cm x 85 cm x 120 cm)
General Name	Electric Massager

Customer Support Guidelines

If you encounter minor malfunctions or errors, please refer below before contacting the customer center.

Problem	Causes	Solutions
Massage chair does not operate even when the power is on	Did not press the Power button on the controller or inner key	Press the Power button
	Program is not selected	Select and run the program
	Power is not properly plugged in	Properly plug the power into the socket
	Power plug/cable is damaged	Please contact the after-service center
	Fuses are burnt	
Electrical circuit is malfunctioning		
Massage chair makes noises during the operation	General machine noises - Air pump vibration, air inlet/outlet noises - Noises due to airbag inflation - Solenoid valves opening/closing - Sheet friction	The noises are general machine noises. There is nothing wrong with the product
	Used the massage chair for a long time	Restart the machine (after 30 min)
	Tear from long-time usage	Please contact the after-service center
Machine suddenly stops during the operation	Accidentally pressed the OFF button	Press the Power on
	Massage time has ended	Restart the machine (after 30 min)
Machine suddenly stops during the operation	Check the object detection sensors and whether there are any objects caught between parts	Remove the object and restart the machine
	Excessive usage or shock	Restart the machine (after 30 min)
Massage balls caught or crashed into the interior sheet during the operation	Frictions between the massage balls and sheets	Rubdown technique generates such a phenomenon due to massage balls so it's not a problem
Does not go back to the original position	Excessive use	Please contact the after-service center
Overheated controller	Use the massage chair for a long time	Restart the machine (after 30 min)
Overheated power cable	Excessive load	Restart the machine (after 30 min)
	Other miscellaneous causes	Please contact the after-service center
Airbags do not activate	Air hose disconnected	Please contact the after-service center
	Air-related power cord is disconnected	